

REV.	REVISED DESCRIPTION	DATE	DRAWN
1.0	FIRST RELEASE	2025.01.21	ZLJ

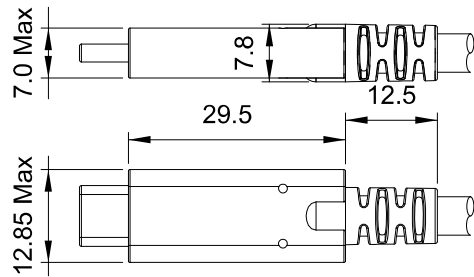
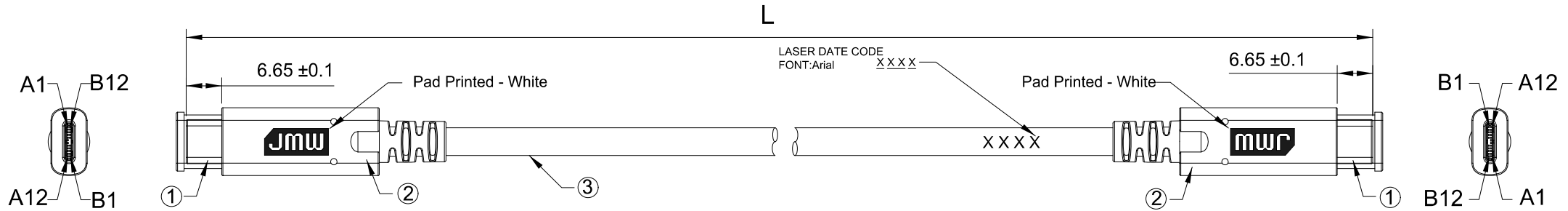

CONNECTION

USB Type-c with IC Plug

USB Type-c with IC Plug

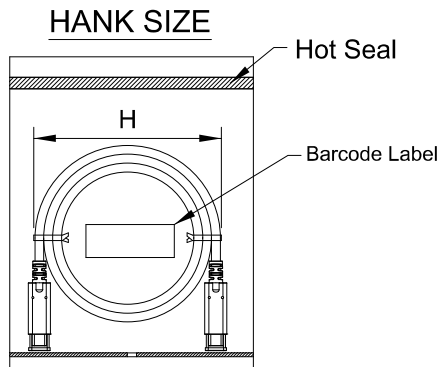
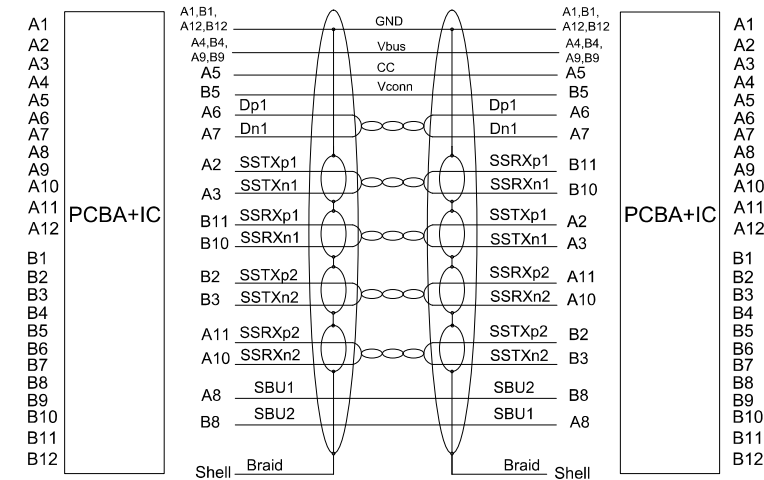

1PC/ PE Bag

PART NO.	Barcode No.	LENGTH(L)	HANK SIZE(H)
JM-U3CC03/60W-V2	4522686011812	3000±80	140±10

ELECTRIC TESTING

NO	PARAMTER	TEST CONDITIONS
1	FUNCTION TESTING	100 %

ITEM	SPECIFICATION	MODEL
③	[(1/0.27Bc+FOAM-PE)*1P+1/0.254Tc+AL/Mylar&Hot Mylar]*4+ [(7/0.08Tc+FOAM-PE+SKIN)*1P+AL/Mylar&Hot Mylar]*1+(7/0.06Tc +HDPE+Al/Mylar)*4C+(19/0.20Tc+FEP)*1C+Filler+7/0.127Tc* 2pcs+AL/Mylar+16/14/0.08Tc 90%*1C OD=5.3±0.20mm Jacket=Black TPE with White Text:SuperSpeed USB 3.1 E301195 AWM 21104 80°C 30V VW-1	
②	PVC-UL94V-0 Black 60P	
①	USB Type - C Plug-Nickel Plated (Pin:AU 30u") +Type C PCBA (Red)- with IC	CYT-4561 CYT-4602

TOLERANCES UNLESS OTHERWISE STATED
X. = ± 1
X.X = ± 0.2
X.XX = ± 0.1
TOOLING DECIMALS ANGLES
X. ± 0.3 ± 1°
X.X ± 0.2 ± 0.5°
X.XX ± 0.1 ± 0.5°

P/N:	JM-U3CC03/60W-V2	SIZE	A4	REV	1.0
DESCRIPTION	USB 3.1 (GEN2) C TO C Active Cable	UNIT	mm	SCALE	NO
PRODUCT	(3M 3A/20V/60W)	PAGE NO		1/1	
		DATE		2025.01.21	

JAPAN MATERIAL Co.,Ltd.